

Anna Bos

CSU Accelerator Facility Internship

Summer 2013

Introduction

The Electrical and Computer Engineering program at Colorado State University (CSU-ECE) is creating a particle accelerator program to further educate students, advance accelerator technology, and encourage the use of accelerators in industrial applications. The team is headed by Dr. Sandra Biedron and Dr. Stephen Milton, and now includes research scientist John Harris and post-doctoral researcher Jorge Martínez. The team for summer 2013 also includes several graduate students from CSU and nine high school and undergraduate interns. This is a significant expansion from the three interns involved in summer 2012.

The high-energy beams created by particle accelerators can be used in medical images, radiation treatment, and sterilization of food. They can also be used in industrial fabrication instead of metal coating, which would significantly reduce power usage by factories. Furthermore, such beams can be used for defense and security. The CSU-ECE group intends to initially use the beam created by the accelerator to drive a free electron laser (FEL). The bunches of electrons from the accelerator will pass through an undulator coherently, creating a laser.

The accelerator we will be using is a small linear accelerator (LINAC), donated by the University of Twente in the Netherlands. The Titanium-Sapphire laser that will be used to power the photocathode was donated by Boeing, an aerospace and defense company based in Chicago. During summer 2013, the group continued to work in CSU's Engineering Research Center at the Foothills Campus. However, the accelerator will soon be housed next door in the advanced beam facility that was completed in summer 2013. For now, various parts of the accelerator set-up are housed in the F-wing of the ERC, which formerly contained a wind tunnel for the aerodynamics research program.

This summer I specifically studied the cathode preparation chamber for the accelerator. It will contain a metallic photocathode that will generate electrons via the photoelectric effect when struck by

the beam of the Ti:Sapphire laser. I also spent a couple weeks studying the work of Lauren Rand, a graduate student developing a thermionic cathode with a very low work function. While not related to the accelerator project, it was relevant in that it gave me a better understanding of electrified, electron emission, quantum efficiency, and solid state chemistry.

Work on the Accelerator

The RF power for the accelerator begins with a large number of alternating capacitors and inductors. This system creates a voltage pulse from many smaller pulses of varying wavelength sine wave functions. Ideally, if an infinite number of these smaller pulses are layered, the resulting pulse is square when plotted as a function of time. Such a pulse is desirable to create a sudden bunch of electrons, as opposed to the longer, less uniform bunch that would be generated from a voltage pulse with a sine function. This electron bunch is emitted from a thermionic cathode at one end of the klystron. A thermionic cathode is similar to a photocathode, except that the electrons are excited via heat energy instead of photons. As the bunch of electrons travels through the RF (radio frequency) cavity of the klystron, the voltage pulse of the cavity causes more voltage to be applied to the tail end of the bunch than the head, causing it to compress into a more acute wave. These waves are then used to create voltage pulses in the RF cavity of the accelerator.

As the beam from the laser hits the metal cathode at the back of the accelerator, some of the photons' energy is absorbed by the electrons in the cathode, exciting some of them enough to be emitted from the atoms themselves. The higher the energy level of an atomic electron, the farther away from the nucleus it orbits. If an electron has enough energy, it will leave the nucleus altogether, creating an ion. This is known as the photoelectric effect. The ratio of electrons emitted to photons applied is called quantum efficiency.

The free electrons are then swept through the accelerator by an electromagnetic field. The voltage waves generated by the klystron are applied to the RF cavities of the accelerator, causing them to

alternate in voltage. The pulses from the laser on the cathode that create electron bunches are timed so that an electron bunch is emitted as the first half-cavity is polarized so the voltage going from the cathode to the LINAC is negative. The voltages alternate throughout the cavities (in the case of our LINAC, five and a half) and switch polarities as the electron bunch moves forward, creating electromagnetic fields that continually accelerate the bunch towards the end of the RF chamber.

When the electron bunch exits the LINAC, it is passed through a series of quadrupole magnets to keep the beam focused. The farther beam is from the source, the greater its radius. This is because not all the electrons have a momentum straight down the path of the beam. The quadrupole magnets consist of four poles, two north and two south, set so that like poles are diagonal from each other. The quadrupole will compress the beam along one axis, depending on the orientation of the poles. Alternating orientations of the quadrupoles narrow the beam in both dimensions. Figure 1 shows a diagram of this process. Note that the diagram is ideal and that the cross section of the beam is not really circular. Passing the beam through a dipole magnet will focus it in either direction, depending on the orientation of the poles.

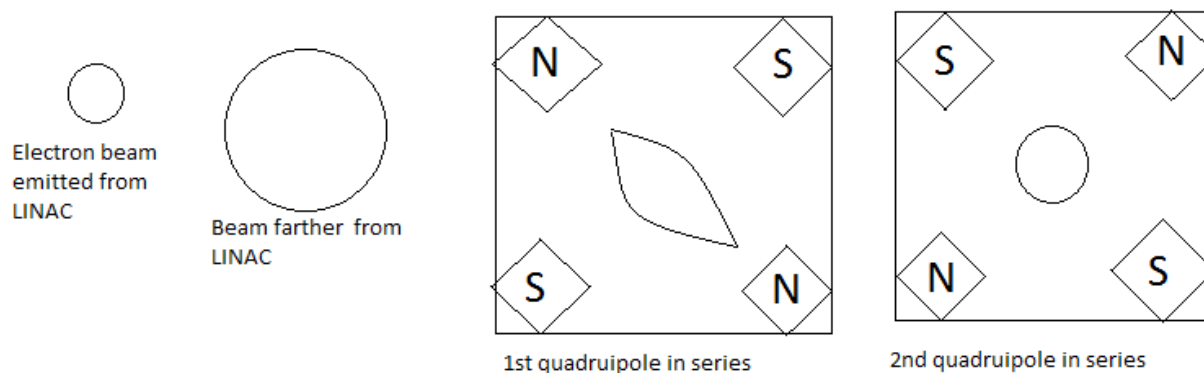

Figure 1

To create an FEL, the beam must be passed through a series of alternating magnetic fields that will wiggle the beam in a sinusoidal path. The changes in acceleration cause emission of photons, specifically synchrotron radiation. The electron beam is already in phase as bunches. Therefore, the

photons are emitted in coherent bunches of virtually the same wavelength. Varying wavelengths would be produced if the electrons not already synchronized. The advantage of an FEL over other lasers is that the wavelength can be adjusted by altering the electron beam or the magnetic fields through which it passes. Other lasers, such as semiconductor, gas, or crystal lasers, can only produce certain discrete wavelengths. In these cases, photons are emitted as electrons drop from one discrete energy level to another, the specific values depending on the material used.

During summer 2012, the interns focused mainly on creating a setup for the Ti:Sapphire laser, an RF cavity test stand, and a monitor for the magnetic field put out by the quadrupole magnets. In summer 2013, our focuses have been developing the control systems, designing a shield wall and interior layout of the accelerator lab, continuing work on the Ti:Sapphire laser, setting up the cathode chamber, and designing a website for the program. Additionally, many of the graduate students and a couple of the interns attended the USPAS (United States Particle Accelerator School) hosted by CSU for two weeks.

As part of the work on the control systems, some students worked on improving the RF cavity test from last summer. They also searched through numerous documents left to us by Twente, and installed and upgraded the computer software. Work on the laser has included setting up a terahertz kit. Because most lasers are limited to certain wavelengths, very few can produce radiation in the tera-hertz frequency range, that is, electromagnetic waves in the long infrared/short microwave region. The optics from the kit create a beam in that frequency. Stray radiation from the setup is a potential health risk, so the accelerator must be surrounded by a concrete shielding wall. Some of the interns spent weeks designing a model of the new facility room and the shield wall. By doing this, they were able to visualize and plan how arrange huge concrete slabs in a pre-constructed building via forklift. They also researched potential suppliers for materials and equipment. Furthermore, some of the interns have also created a website for the accelerator program, which includes researchers, documentation, and the facility, among other things.

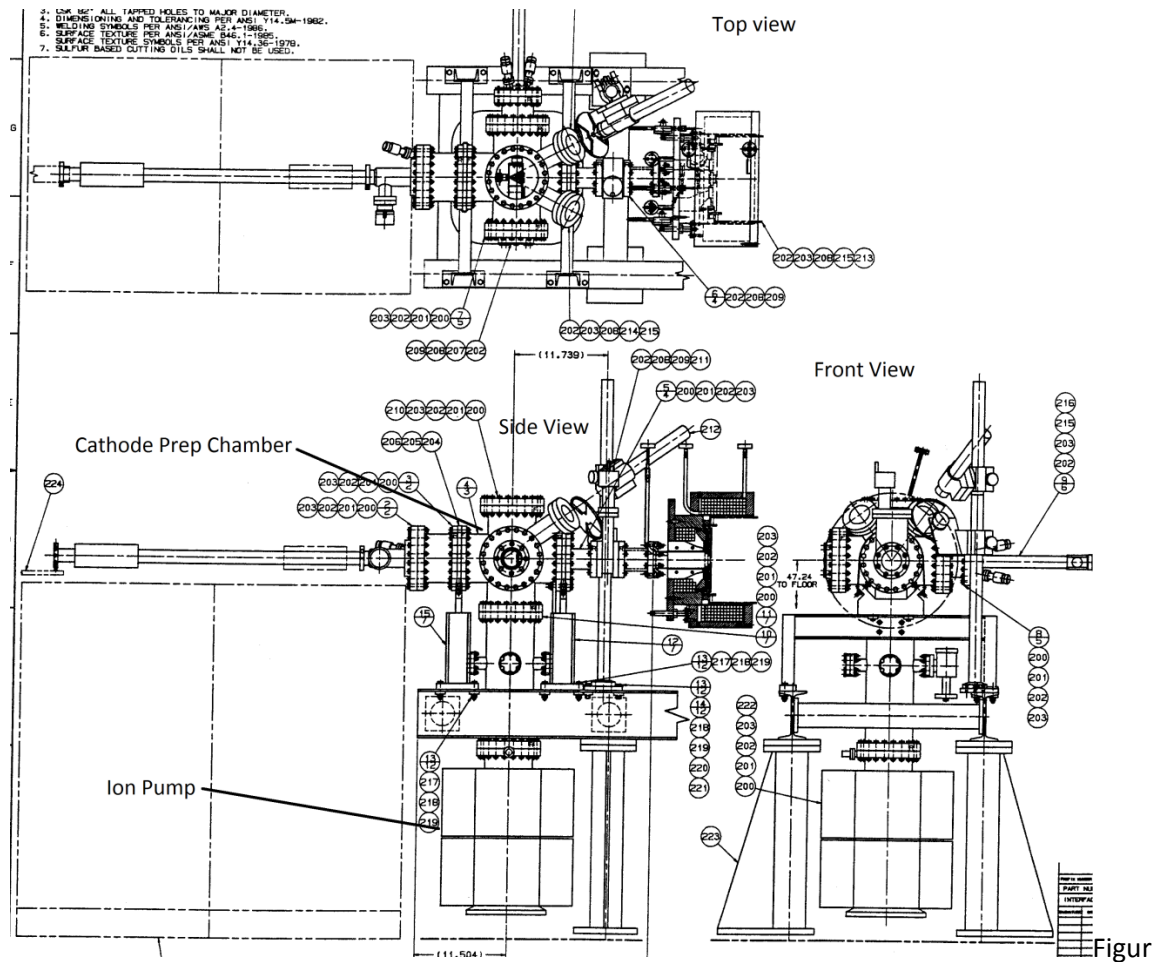

e 2¹

My focus in this project was the cathode preparation chamber, as seen in figure 2. The cathode chamber rests on top of the ion pump, connected by the vacuum chamber. To maintain cathode efficiency and extend the machine's lifetime, the system must be operated under very low pressure, around 10^{-9} tor. To do this, a roughing pump creates a fairly good vacuum (about 10^{-6} tor). The ion pump (figure 3) then sends a temporary cloud of electrons from an anode into the remaining gas, which ionizes the molecules. The ions are then propelled towards a chemically active cathode (commonly titanium) and are either physically imbedded or chemically absorbed. The ion collisions cause some of the cathode material to be sputtered onto the anode, creating more surface for further absorption of neutral molecules. (Some ions gain an electron from the cathode and then rebound and physically imbed in

another surface). Gases such as carbon monoxide chemically react with the cathode, while other such as hydrogen and helium physically imbed². The net result is a much better vacuum than what can be produced mechanically.

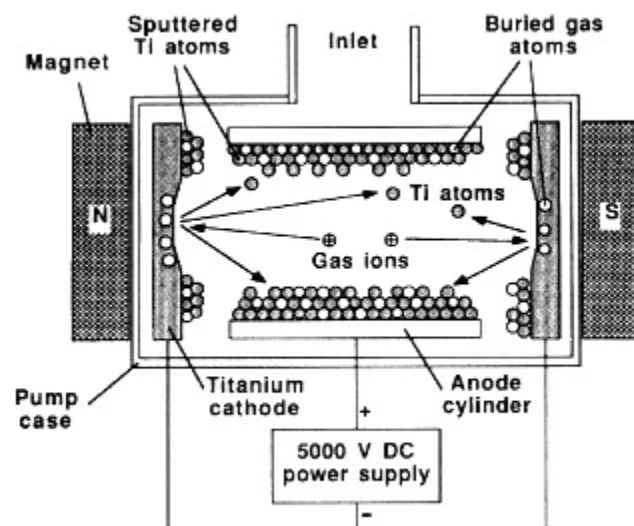
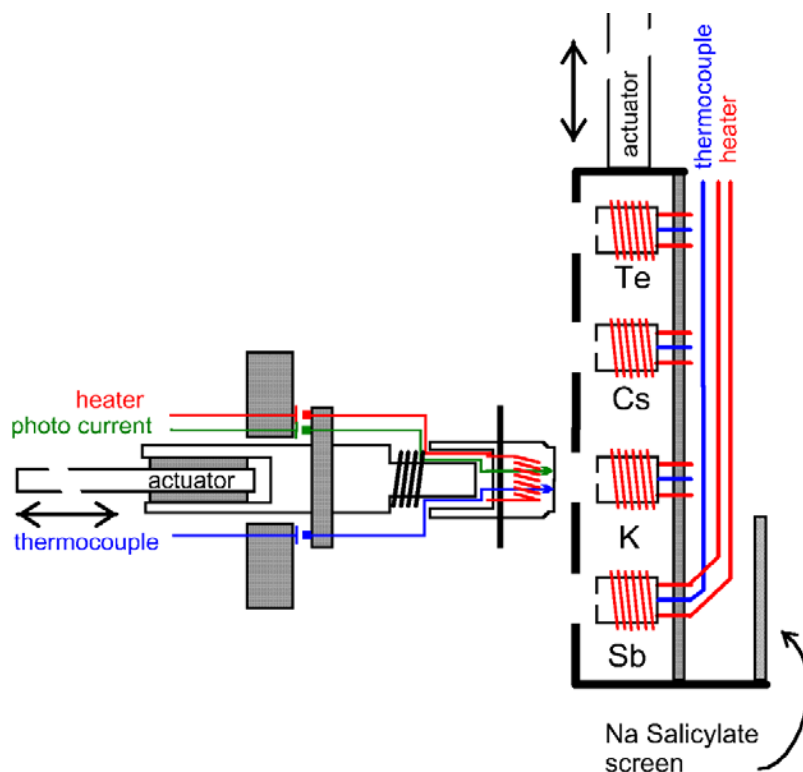

Figure 3³

The cathode preparation chamber contains the cathode itself, various heating elements, and the metals to be evaporated onto the cathode (figure 4). Under high vacuum, alkali metals, semimetals, or non-transition metals are heated to a gaseous phase and then they re-solidify onto a metal substrate. (Substrate in this case means a physical base and not a chemical reactant.) Molybdenum is an ideal substrate. It is extremely hard and barely expands with heat⁴. This is beneficial in that the first layer often deposited is Tellurium, which forms an amorphous structure that cracks easily. Combinations the students at Twente found most useful for the cathode were Cesium and Tellurium (Cs_2Te), Potassium and Tellurium, (K-Te), and all three together (Cs-K-Te). Antimony (Sb) was also used in some combinations, though these did not produce as good of results. Cs-K-Te tended to have the highest initial quantum efficiency (QE) at the photon intensity of the incident laser, but would degrade much faster with use than Cesium and Tellurium⁵.

Figure 4⁵

Because the system will be under such high vacuum, the pieces for the ion pump, ion chamber, and cathode chamber require very meticulous cleaning. Any residue could lower the vacuum and interfere with the beam. We used a mixture of propanol, ethanol, and methanol, along with Kimwipes and cotton swabs for cleaning. The main focus was obviously to clean the inside pieces that will be under vacuum, but the outer parts needed some attention too, as years of disuse had left them very grimy. It's easier to work on the inner surfaces when dirt from the outside won't be smeared in. We also cleaned parts we ordered from manufacturers. While those parts didn't require nearly as much time, it was important to remove any residual machine oil.

I also spent a lot of time just inventorying parts and looking over diagrams. We were given a set of engineering schematics from Twente as to how to assemble the cathode chamber, but it took a while for me to learn how to interpret the diagrams. Just identifying what various pieces in the storeroom were took time. We were missing some necessary parts, likely not sent in the first place. There were also

some parts that were sent that went with an alternate setup we will not likely be using. Some pieces were broken and needed to be replaced, and others varied somewhat from the diagram. I searched various websites for the part numbers listed in the diagrams to order replacements. Sometimes a company would no longer have the specific part number, since the diagrams were drawn up over 20 years ago, and I would need to find a close substitute. Other times I would know the head corporation, but had to track down distributors. Some parts didn't list a specific company, and I had to search for ones that supplied them.

We also began bolting the pieces of the chamber together. Seals for a vacuum chamber have to be carefully assembled. Both fittings need an acute knife edge without nicks or scratches to properly crush the copper gasket. Copper gaskets were used because they are relatively soft and malleable, providing a tight seal. Each time we gave both parts as well as the gasket a quick final cleaning. After lining them up properly, we started bolting them together by finger-tightening. After that, we went around and tightened each bolt about a quarter turn, working around the seal again and again. The bolting was done in a gradual manner so as to get an even seal on the copper gasket and hopefully not leave any leaks. The real test will be when the chamber is pumped down to low pressure.

Electride Thermocathode

Lauren Rand, a PhD student working with the CEPPE department at the ERC, is developing a thermionic cathode in the form of a $12\text{CaO}\cdot\text{Al}_2\text{O}_3$ (C12A7) electride. While such an electride is well established, Lauren's research is to develop it as a hollow thermionic cathode. An electride is a crystalline structure with a positively charged lattice containing electrons (which replace the native anions). A unit cell for C12A7 (two formula) contains 12 cages, each with a $+1/3$ charge, for a total of $+4$. Part of a unit cell is shown in figure 5. Normally there is one oxygen anion (O^{2-}) per six cages, but in the case of the electride the two oxygen ions per unit cell are replaced by four electrons.⁶ (See figure 5).

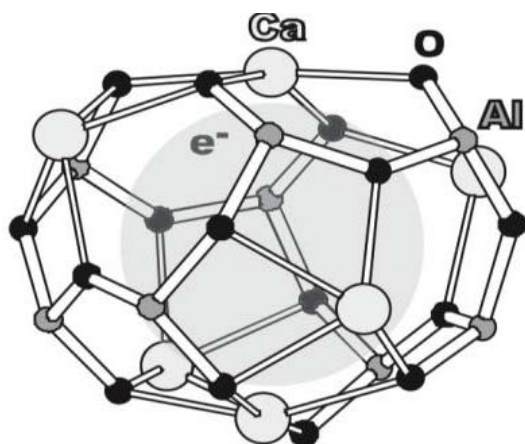
Figure 5⁷

There are multiple ways to synthesize C12A7 electrider. The method that Lauren uses is to heat ground-up precursors CaCO_3 and Al_2O_3 in a 12:7 mixture to $1600\text{--}1800^\circ\text{C}$. This is done in a carbon (graphite) template in a furnace devoid of most oxygen. Though the mechanism is uncertain, carbon anions replace the oxygen anions and then evaporate, leaving their electrons. The graphite sleeve that the electrider is synthesized in is then inserted into a tantalum tube. A mixture of argon gas atoms and plasma is run through the tube and ignited. This is performed in an otherwise vacuum chamber. A nearby anode draws out the stream of electrons. The current of the electron stream is measured, as well as the voltage between the anode and the cathode. The voltage can be used to estimate the temperature of the reaction from a table of voltages with corresponding temperatures for C12A7.⁷ An ampere meter is in place to determine the current put out for a given work function. Figure 6 shows a general outline of the set up. In the case of Lauren's cathode, the heat source is needed only to ignite the plasma.

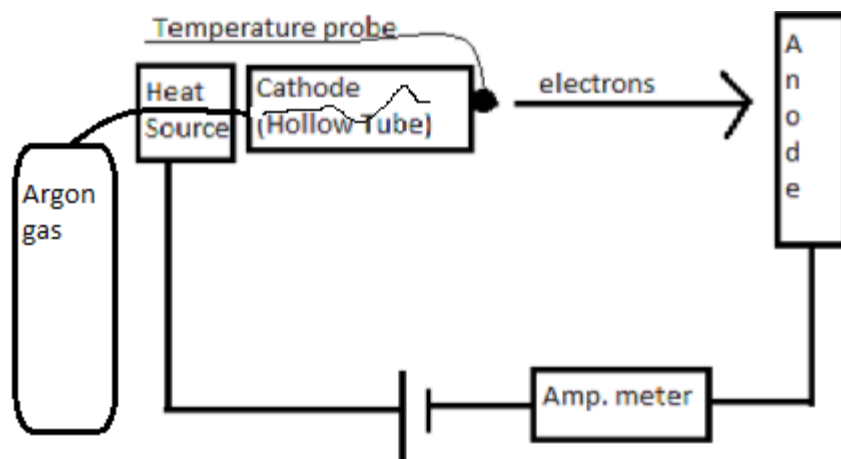

Figure 6

While the plasma is ignited to begin the reaction, the cathode itself does not need to be externally heated and can start at room temperature. (The reaction and the plasma will heat up the cathode). This is an exception among hollow thermionic cathodes, and a benefit, as less energy is required. Another benefit is the relatively low work function, measured by the operating temperature of the cathode. Some common cathodes do not produce significant emission until 1300°K or even 1900°K . Theoretically, C12A7 could operate as low as 400°K , though Lauren has yet to achieve such good results. In terms of voltage, many hollow cathodes operate around 3 electron volts (eV), the work function C12A7 as an electride has been measured to be as low as 0.6 eV. It is also the only inorganic electride stable at relatively high temperatures (up to almost 1300°K).⁷ In the long run, C12A7 hollow cathodes could potentially be used to generate ion streams to propel spacecraft; it would be much more fuel efficient than combustion of organic material. Dr. Biedron is also hoping to see the electride tested as a photocathode that could be used for FEL's.

My involvement was mainly shadowing Lauren and studying her work. She was mostly done with experimental research and ready to focus on writing papers when I came. I saw her perform a few final tests where she would monitor the work function over time. It wasn't as consistent as she wanted. However, she did realize that poor conduction between the plasma and the anode gave an appearance

of a higher work function. Lauren wants to test the electride she synthesized with the x-ray diffraction (XRD) offered at the Stanford Synchrotron Radiation Lightsource (SSRL). The huge circular particle accelerator gives off extremely bright x-rays from the accelerating electrons, similar to an FEL. There are multiple beamlines available for different uses. To use a beamline, one usually must submit a detailed proposal and have it approved months in advance. Dr. Biedron set up a conference call for Lauren and herself with Dr. Piero Pianetta, the interim director at SSRL. Lauren explained her work to him and how she wants to use high-powered XRD to confirm that her compound is $12\text{CaO}\cdot 7\text{Al}_2\text{O}_3$. The x-ray photoelectron spectroscopy (XPS) machine at CSU could not give high enough resolution to confirm the correct aluminum-oxide compound. When we applied for beam time, Dr. Pianetta said to submit a brief letter of intent, because he already knew about Lauren's work and she would only need one eight-hour session.

I worked on drafting a letter of intent for Lauren, though it was a learning experience for me, not help for her. She had to edit my work multiple times. I did look up the form for the letter, and some differences in precision between the accelerator at SSRL and the machine at CSU. XRD and XPS can work in a similar manner. When x-rays strike an electron, they will glance off at an angle. The scattered x-rays are picked up by detector screens. The angle at which the x-rays scatter for a given electron varies depending on the atom it's bound to and what compound that atom is a part of. By comparing the results to literature values, one can verify what compound is being tested. Clearer results are obtained by a brighter beam intensity. The beam intensity is proportional to the current of accelerated electrons. The current of the XPS machine at CSU is 20-30mA, while that of SSRL is 300-500mA.

Conclusion

A lot of work still has to be done on the accelerator, and it likely won't be in use until at least early 2014. After I leave, someone will continue working on the cathode chamber, assembling the

electrical wiring and deciding which elements to use for the cathode. The control systems will still have to be set up. The shield wall will have to be built in the new building, the various LINAC components brought in, and all the components assembled together mechanically and electrically. When the accelerator finally is up and running, an FEL will be created with the beam produced.

While I didn't do original, publishable research, I learned a lot this summer. I got a lot of experience going through engineering diagrams, ordering parts, and working with wrenches, nuts, and bolts. I gained an appreciation for particle accelerators and their applications from listening to the professors and graduate students here. I also learned about the quantum physics behind lasers and accelerators from my own studies. The closest I came to studying chemistry was Lauren's electronegativity and the reading I did about similar electronegativities. I was able to see a lot of practical uses for many of the rarer transition metals, lanthanides, and semi-metals in electrical engineering.

References

1. Diagrams for University of Twente for Cathode Preparation Chamber, made by Los Alamos National Laboratory
2. (April 19, 2013) Ion Pump (physics). *Wikipedia*. http://en.wikipedia.org/wiki/Ion_pump_%28physics%29
3. Wittke, James H. (2008). Introduction. *Northern Arizona Univeristy*. <http://www4.nau.edu/microanalysis/Microprobe-SEM/Instrumentation.html>
4. (July 6, 2013). Molybdenum. *Wikipedia*. <http://en.wikipedia.org/wiki/Molybdenum>
5. Verschuur, Jeroen W.J. (May 2004). Short overview of TEUFEL-project (power point). **For more information, see the drop box, CSU, FEL, UTwente info, papers*
6. Kim, Sung-Wng, et. al. (2007). Fabrication of room temperature-stable $12\text{CaO} \cdot 7\text{Al}_2\text{O}_3$ electride: a review. *J. Mater Sci: Mater Electron*. 18: S5-S6
7. Rand, Lauren P., et. al. (2013). C12A7 Electride Hollow Cathode. Dep. of Mechanical Engineering, Colorado State University.